

Electrical Specifications

Parameter	Symbol	Min.	Typ.	Max.	Units	Conditions
Nominal Frequency		1.5		125	MHz	See Note 1

Frequency Stabilities

Parameter	Symbol	Min.	Typ.	Max.	Units	Conditions
Frequency Stability	$\Delta F/F$	See Ordering Information			ppm	
Aging			± 3		ppm	1 st year
			± 2		ppm/year	Thereafter

RF Output

Parameter	Symbol	Min.	Typ.	Max.	Units	Conditions
Output Type		HCMOS Compatible				
Output Load				50/10	pf/TTL	See Note 2
				50	pf	1.500 to 50.000 MHz
				15	pf	50.001 to 67.000 MHz 67.001 to 125.000 MHz
Symmetry		See Ordering Information			%	$\frac{1}{2} V_{DD}$
Logic "1" Level	V_{OH}	90% V_{DD} $V_{DD} - 0.5$			V	HCMOS Load
					V	TTL Load
Logic "0" Level	V_{OL}			10% V_{DD}	V	HCMOS Load
				0.5	V	TTL Load
Rise/Fall Time	T_R/T_F			10	ns	See Note 3
				3	ns	1.500 to 67.000 MHz 67.001 to 125.000 MHz
Output Current				± 16	mA	
Standby/Tristate Function		Input Logic "1" or floating: Output active				
		Input Logic "0": Output disables to high-Z				
Startup Time				10	ms	

Operating Voltage and Current

Parameter	Symbol	Min.	Typ.	Max.	Units	Conditions
Supply Voltage	V_{DD}	4.5	5.0	5.5	V	
Supply Current	I_{DD}			20	mA	1.500 to 20.000 MHz
				35/45		20.001 to 50.000 MHz
				65		50.001 to 125.000 MHz

Temperature

Parameter	Symbol	Min.	Typ.	Max.	Units	Conditions
Operating Temperature	OTR	See Ordering Information			°C	
Storage Temperature	STR	-55		+125	°C	

Additional Parameters

Parameter	Symbol	Min.	Typ.	Max.	Units	Conditions
Random Jitter	Rj		5	12	ps RMS	1-Sigma

Notes

Note 1	Consult factory for availability of higher frequencies.
Note 2	HCMOS Load - See Load circuit diagram. Consult factory with nonstandard output load requirements.
Note 3	Rise/Fall times are measured between 0.5 V and 2.4 V with TTL load, and between 10% VDD and 90% VDD with HCMOS load.

Features and Applications

Features	Applications
Leadless Ceramic Package/Seam Sealed	Avionics and Aerospace
Tristate or Standby function options	Communication and Navigation
Stabilities to ±20 ppm	Military Radios
MIL-STD-883 Screening	Test & Measurement Equipment
Custom Hi-Rel Screening	Instrumentation and Industrial
Fully RoHS 6 compliant (except Lead Codes L and S)	Measurement Equipment

Environmental Condition

Parameter	Conditions
Mechanical Shock	MIL-STD-202, Method 213, Condition C (100 g's, 6 ms duration, ½ sinewave)
Mechanical Vibration	MIL-STD-202, Method 201 & 204 (10 g's from 10-2000 Hz)
Hermeticity	MIL-STD-202, Method 112, (1x10 ⁻⁸ atm. cc/s of Helium)
Thermal Cycle	MIL-STD-883, Method 1010, Condition B (-55°C to +125°C, 15 min. dwell, 10 cycles)
Solderability	EIAJ-STD-002
Max Soldering Conditions	See solder profile, Figure 1

Load Circuit Diagrams

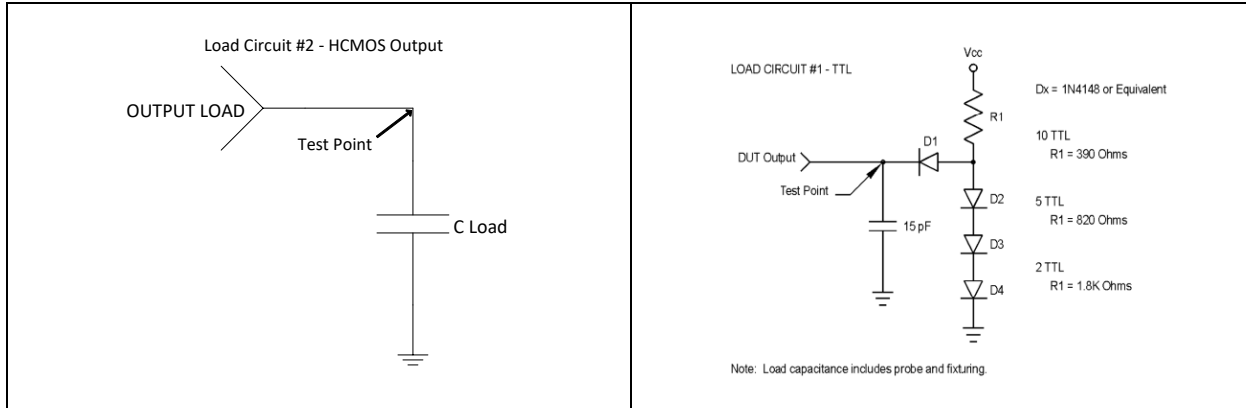

Mechanical and pin out information

Pad	Function
1	N/C. Tristate or Standby
2	Ground
3	Output
4	+VDD

Part Marking	
Line 1	Part number
Line 2	xxMxxxx
Line 3	Myywww

Legend	
M	Mtron
yy	Last digit of year
ww	Week of manufacture
v	Factory code

Graphs/Package Dimensions (N: Leadless Ceramic)

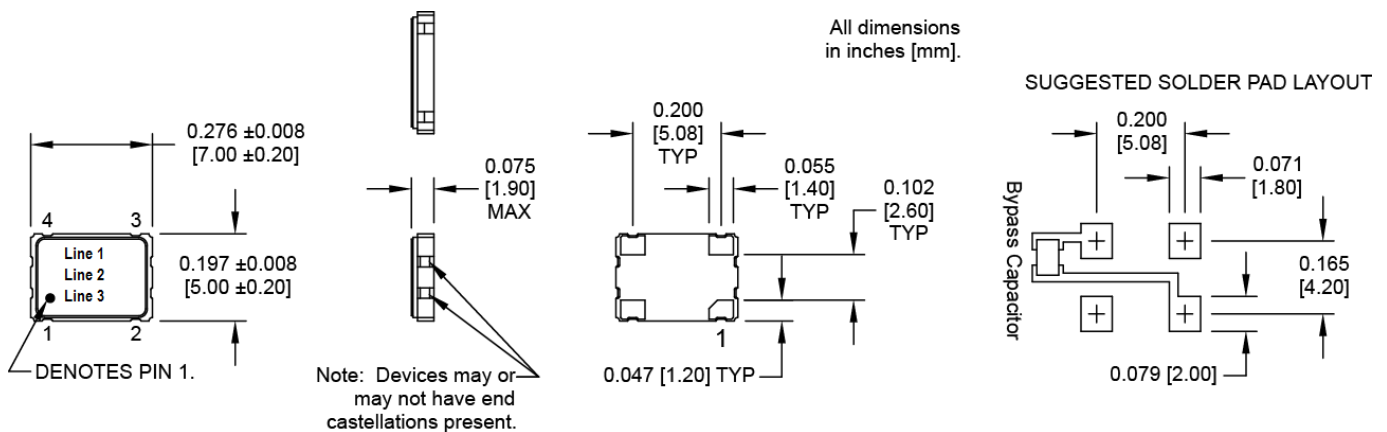

Graphs/Package Dimensions (G or L: Gull Wing)

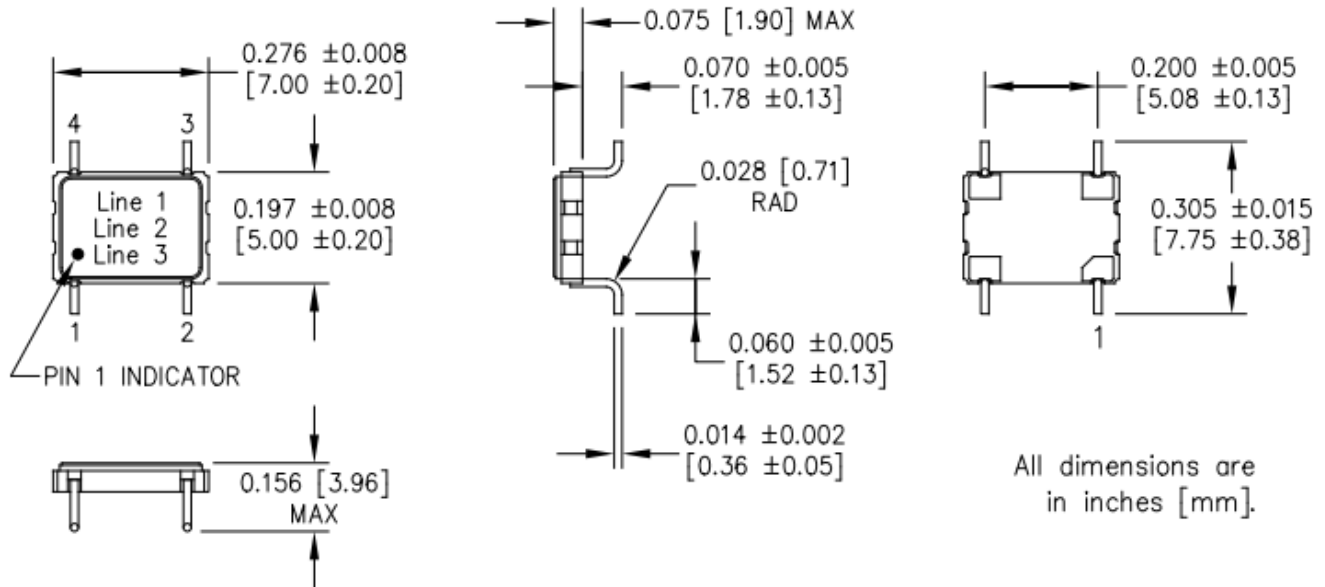

Graphs/Package Dimensions (J or S: Formed J-Leads)

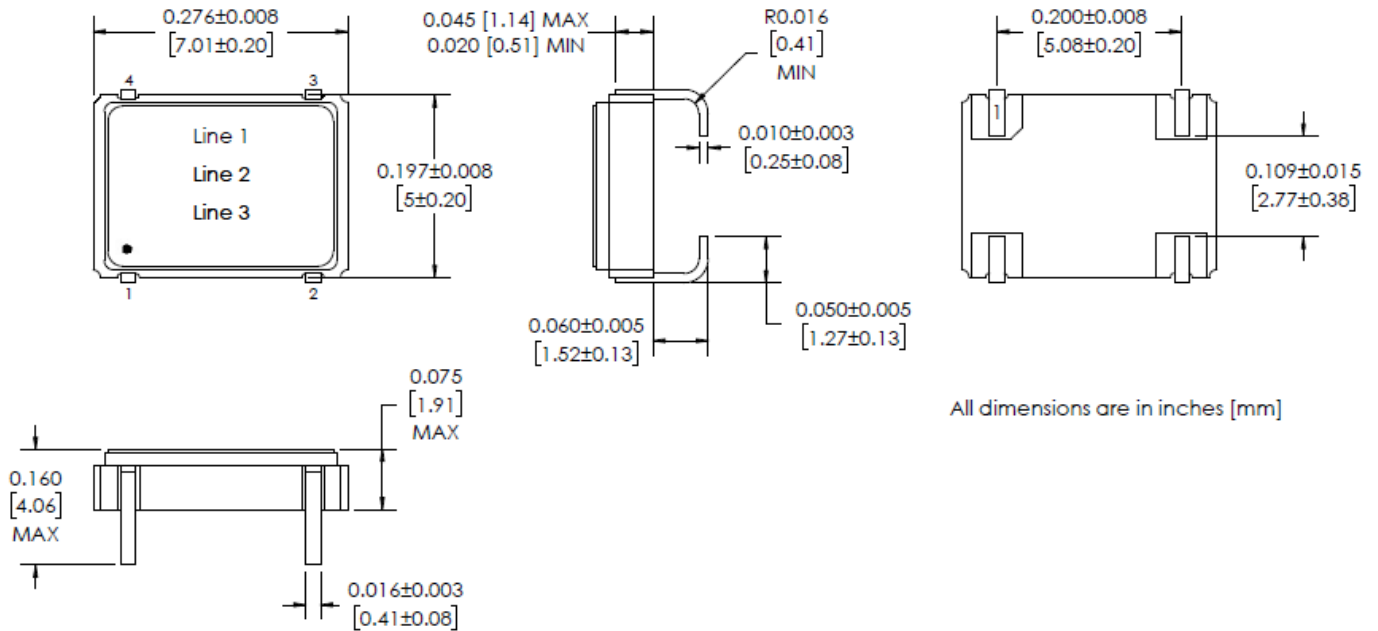

Lead Free Solder Profile

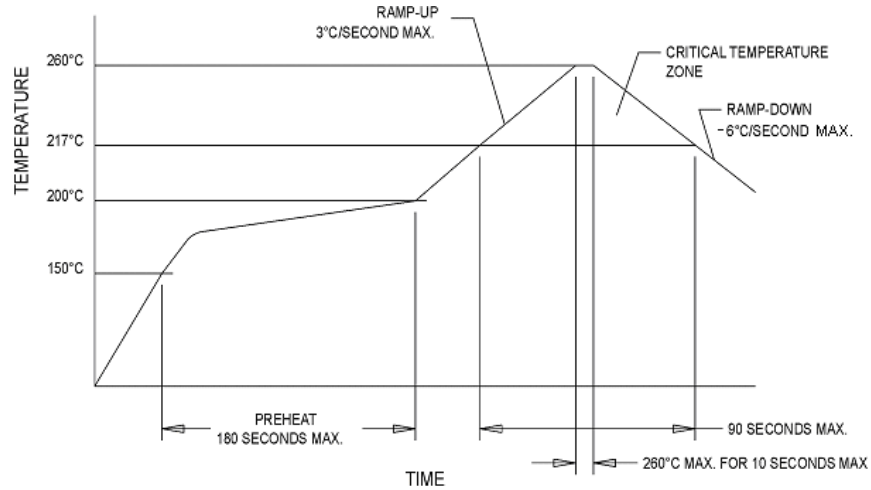
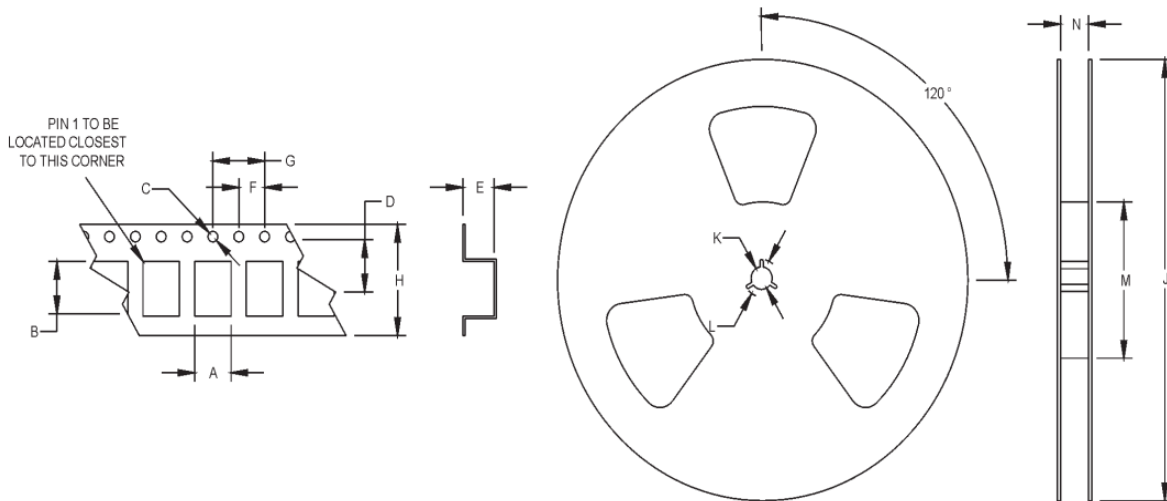

Figure 1

Tape and Reel Specifications (Leadless Ceramic Configuration)

All units in mm



A	B	C	D	E	F	G	H	J	K	L	M
5.32	7.28	1.5	7.5	2.2	4	8	16	178	13.5	24.8	80

Ordering Information

M1 2 3 T C N 00.0000MHz

Product Series	
M1	5.0 V

Frequency (Customer specified)

Temperature Range	
1	0°C to +70°C
2	-40°C to +85°C
3	-55°C to +105°C
4	-55°C to +125°C
5	-10°C to +125°C
6	-20°C to +70°C
7	0°C to +85°C

Package/Lead Configuration	
N	Leadless Ceramic
G	Gull Wing Leads Solder Dipped (SAC)
L	Gull Wing Leads Solder Dipped (SnPb)
J	Formed J-Leads Solder Dipped (SAC)
S	Formed J-Leads Solder Dipped (SnPb)

Stability	
3	± 100 ppm
4	± 50 ppm
5	± 35 ppm
6	± 25 ppm
8	± 20 ppm

Symmetry/Logic compatibility	
A or G	40/60% @ 50% V _{DD}
C	45/55% CMOS

Output Type	
F	Fixed
Q	Standby
T	Tristate

Revision History

3/23/2026 – Revision B